

[www.teknikoffice.co.uk](http://www.teknikoffice.co.uk)

**Teknik**

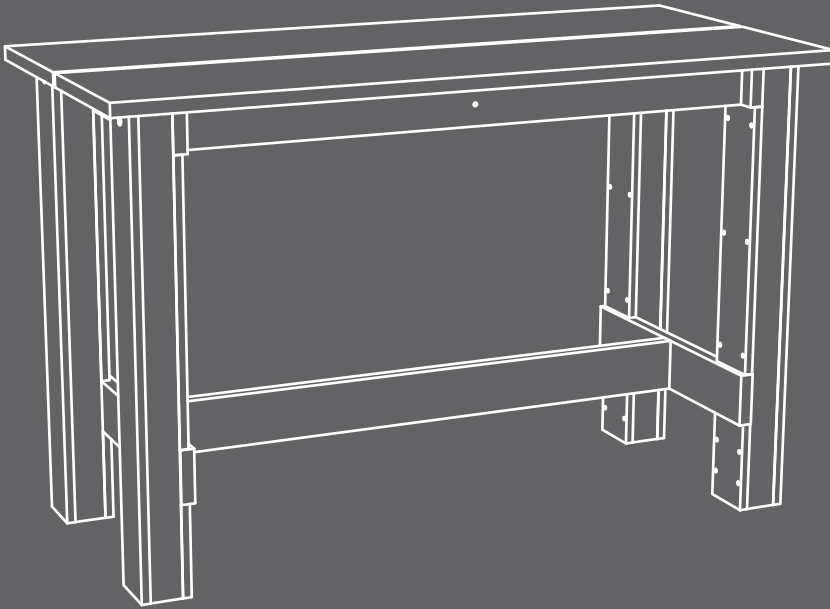

**Welcome** to the  
big kid **table**.

## Counter Height Work Bench Vintage Oak

Model 5427127

Part Identification	3
Hardware Identification	4
Assembly Steps	5-16
Warranty	23

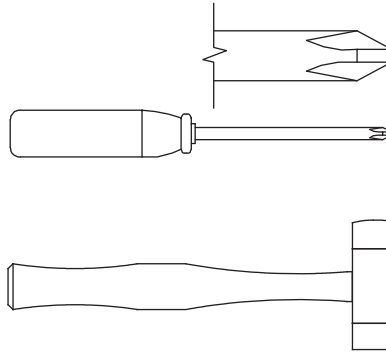

No. 2 Phillips Screwdriver  
Tip Shown Actual Size

Rubber Mallet

## Part Identification

† While not all parts are labeled, some of the parts will have a label or an inked letter on the edge to help distinguish similar parts from each other. Use this part identification to help identify similar parts.

A	TOP (2)
B	LONG LEG PANEL (4)
C	SHORT LEG PANEL (4)
D	OUTER LEG PANEL (4)
E	RIGHT FRONT/LEFT REAR LEG PANEL (4)
F	TOP LONG BRACE (2)
G	TOP SHORT BRACE (2)
H	TOP CENTER BRACE (1)
I	LOWER SHORT BRACE (2)
J	LOWER LONG BRACE (1)
K	LEFT FRONT/RIGHT REAR LEG PANEL (4)

# Part Identification

Now you know  
our ABCs.

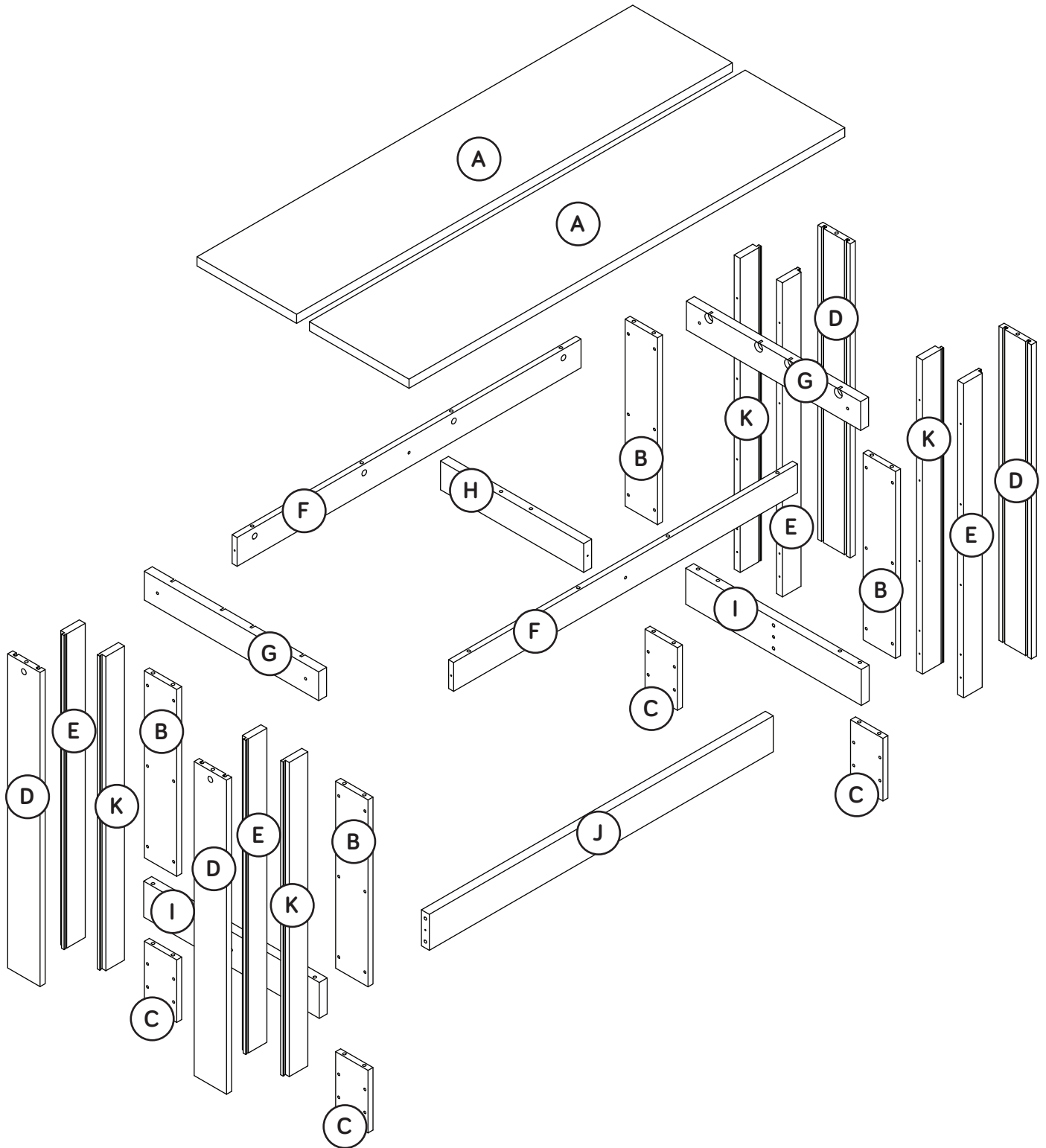

# Hardware Identification

† Screws are shown actual size. You may receive extra hardware with your unit.

**1F** HIDDEN CAM - 14

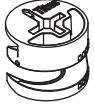

**2F** CAM DOWEL - 14

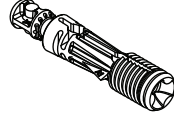

**10F** TWIST-LOCK® FASTENER - 8

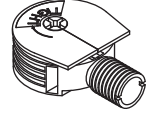

**15F** WOOD DOWEL - 28

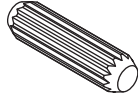

**54M** GLUE - 1



**13P** CAM COVER - 4



**18P** SCREW COVER - 44



**2S** BLACK 1-7/8" FLAT HEAD SCREW - 42

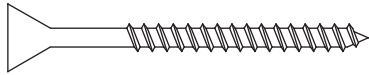

**57S** SILVER 2" FLAT HEAD SCREW - 6

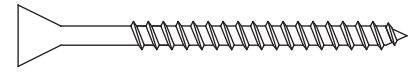

# Step 1

- ✦ Assemble your unit on a carpeted floor or on the empty carton to avoid scratching your unit or the floor.
- ✦ To begin assembly, push a SAUDER TWIST-LOCK® FASTENER (10F) into the large holes in the TOP SHORT BRACES (G).

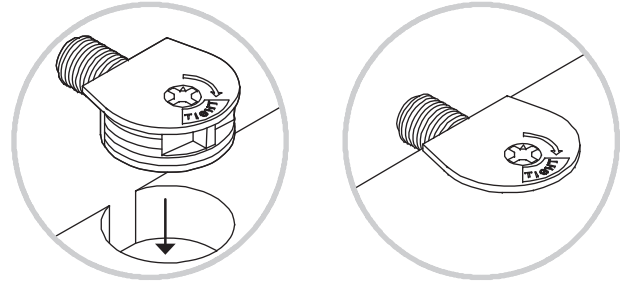

Do not tighten the TWIST-LOCK® FASTENERS in this step.

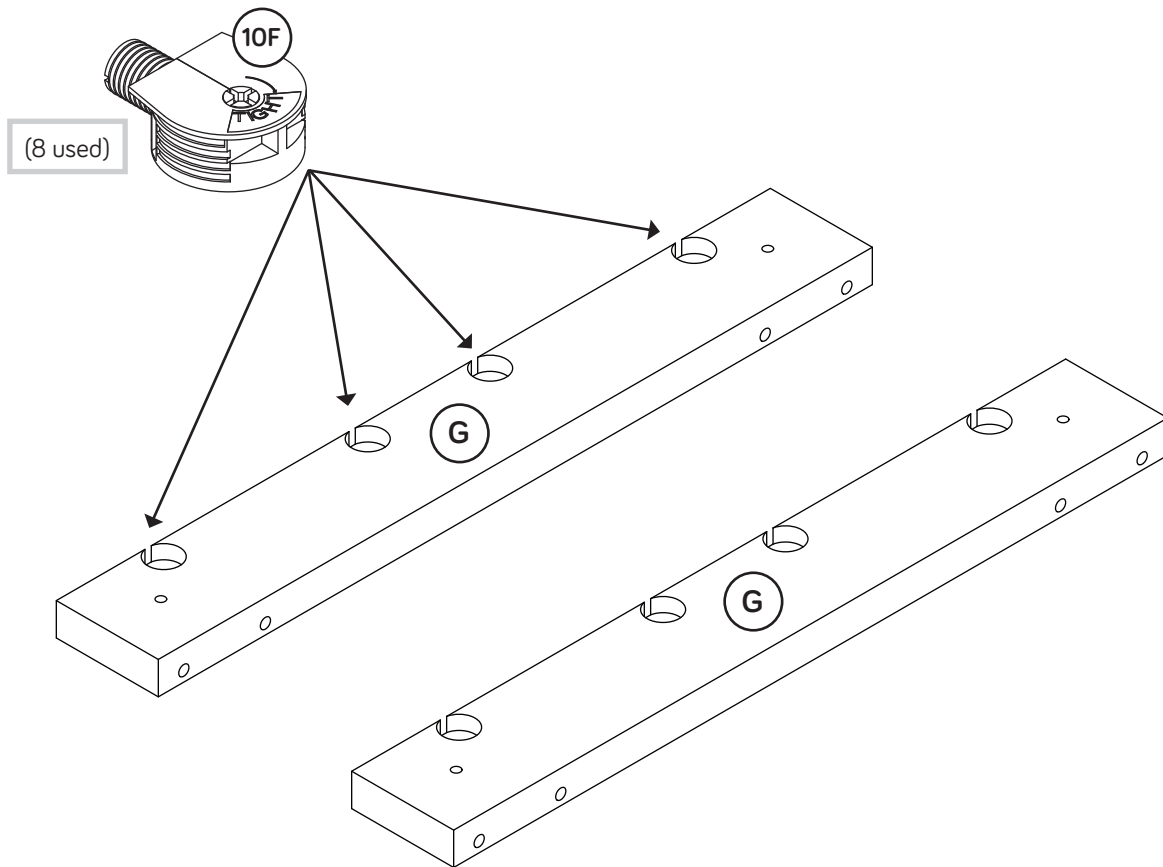

# Step 2

- Push fourteen HIDDEN CAMS (1F) into the OUTER LEG PANELS (D), TOP LONG BRACES (F), and TOP CENTER BRACE (H). Then, insert the metal end of a CAM DOWEL (2F) into each HIDDEN CAM.

Do not tighten the HIDDEN CAMS in this step.

Push these two HIDDEN CAMS completely down in the holes.

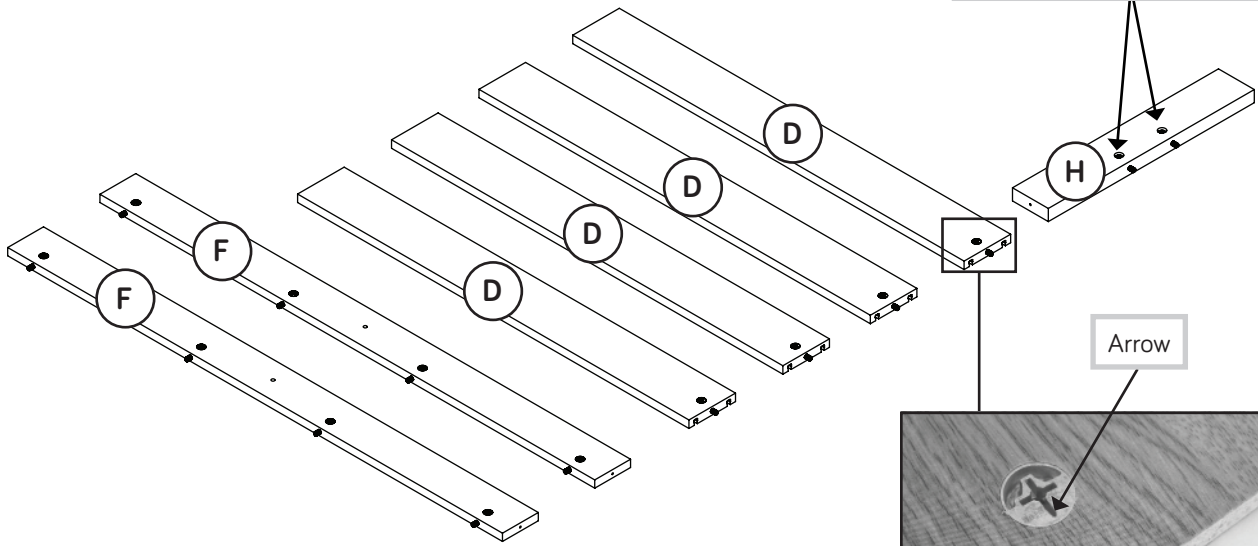

Arrow

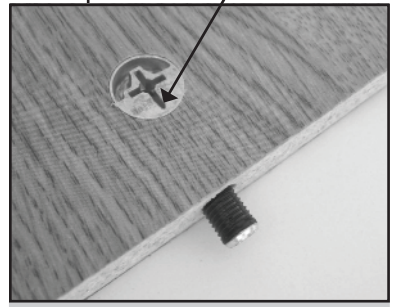

Insert the metal end of the CAM DOWEL into the HIDDEN CAM.

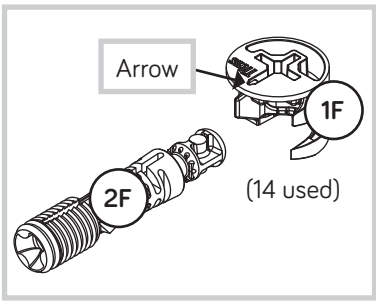

# Step 3

Slide the notched edges of the LEG PANELS (E and K) into the grooves in the OUTER LEG PANELS (D).

**NOTE:** The finished surfaces on the LEG PANELS (E and K) should all face out.

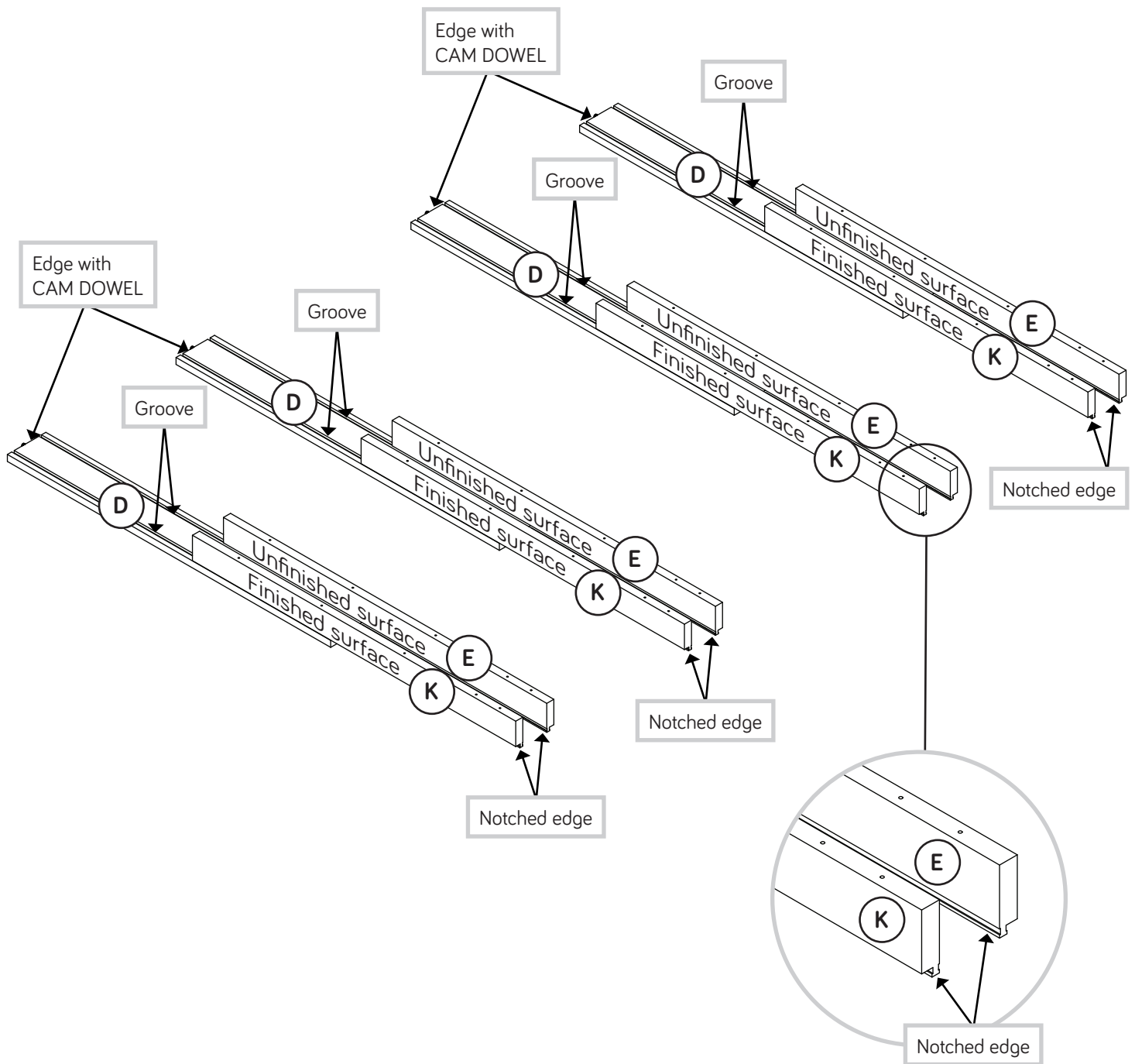

# Step 4

- First, fill the holes in the in the short edges of the SHORT LEG PANELS (C) 1/4 to 1/2 full with GLUE (54M). Then, insert eight WOOD DOWELS (15F) into the holes. Wipe away the excess GLUE.
- Next, fasten the SHORT LEG PANELS (C) to the LEG PANELS (E and K). Use sixteen BLACK 1-7/8" FLAT HEAD SCREWS (2S).

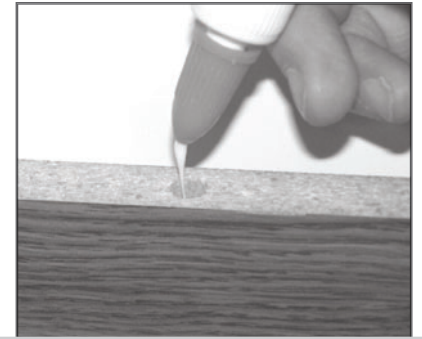

Fill the holes 1/4 to 1/2 full with GLUE.



## ⚠ Caution

Inspect the parts thoroughly before assembling. Disassembly of glued parts is extremely difficult.

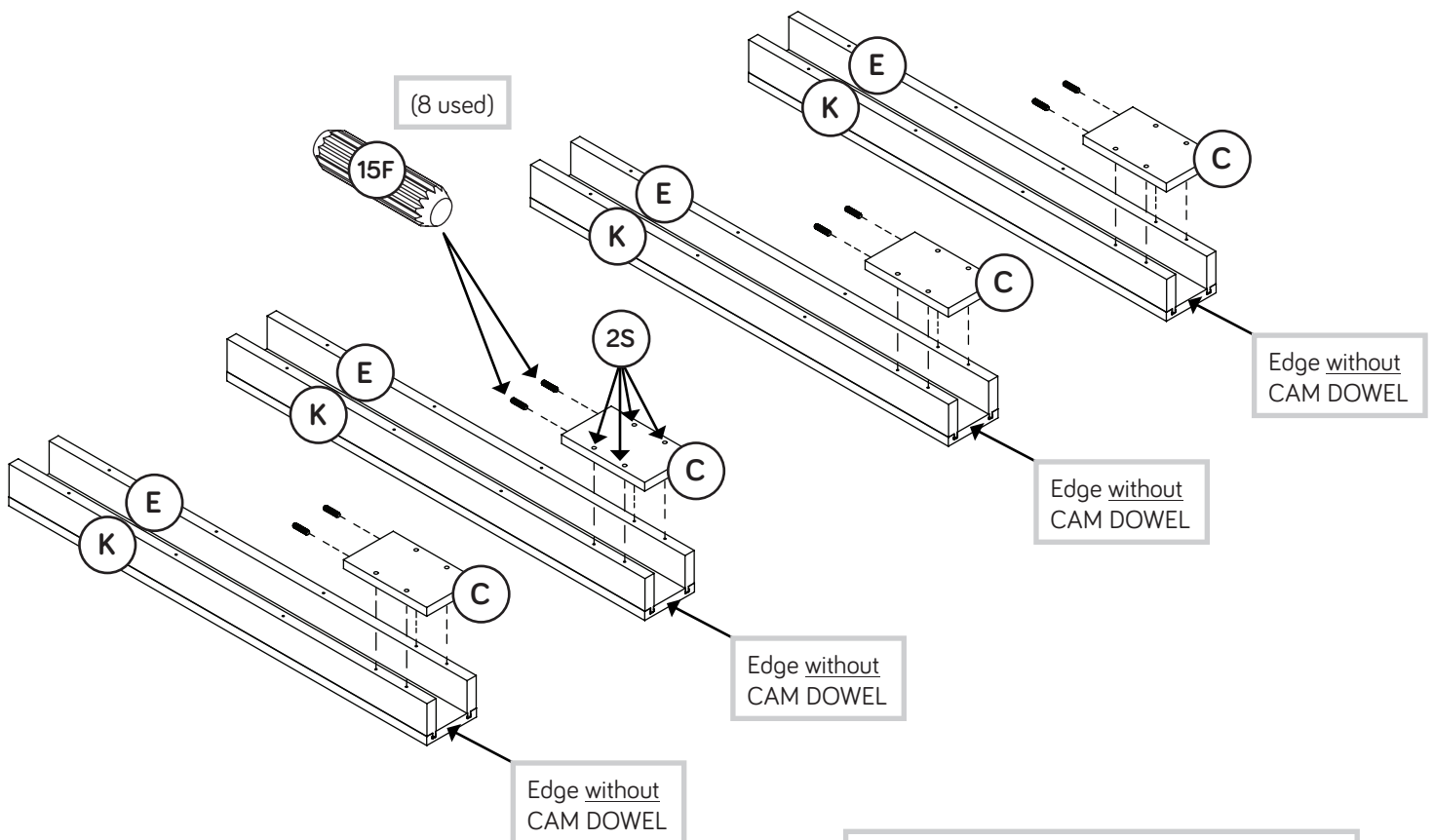

BLACK 1-7/8" FLAT HEAD SCREW  
(16 used in this step)



# Step 5

- First, fill the holes in one edge of each of the LOWER SHORT BRACES (I) 1/4 to 1/2 full with GLUE (54M). Then, insert eight WOOD DOWELS (15F) into the holes. Wipe away the excess GLUE.
- Next, fill the holes in the other edges of the LOWER SHORT BRACES (I) 1/4 to 1/2 full with GLUE (54M).
- Now, place the LOWER SHORT BRACES (I) onto the WOOD DOWELS in the SHORT LEG PANELS (C). Wipe away the excess GLUE.
- NOTE:** Tap into place using a rubber mallet.

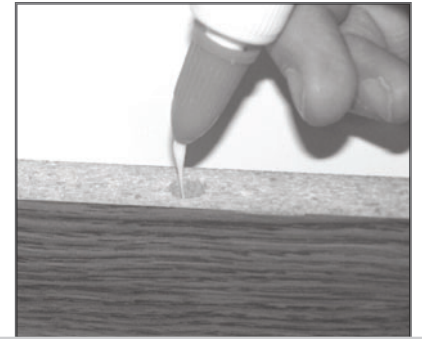

Fill the holes 1/4 to 1/2 full with GLUE.

## ⚠ Caution

Inspect the parts thoroughly before assembling. Disassembly of glued parts is extremely difficult.

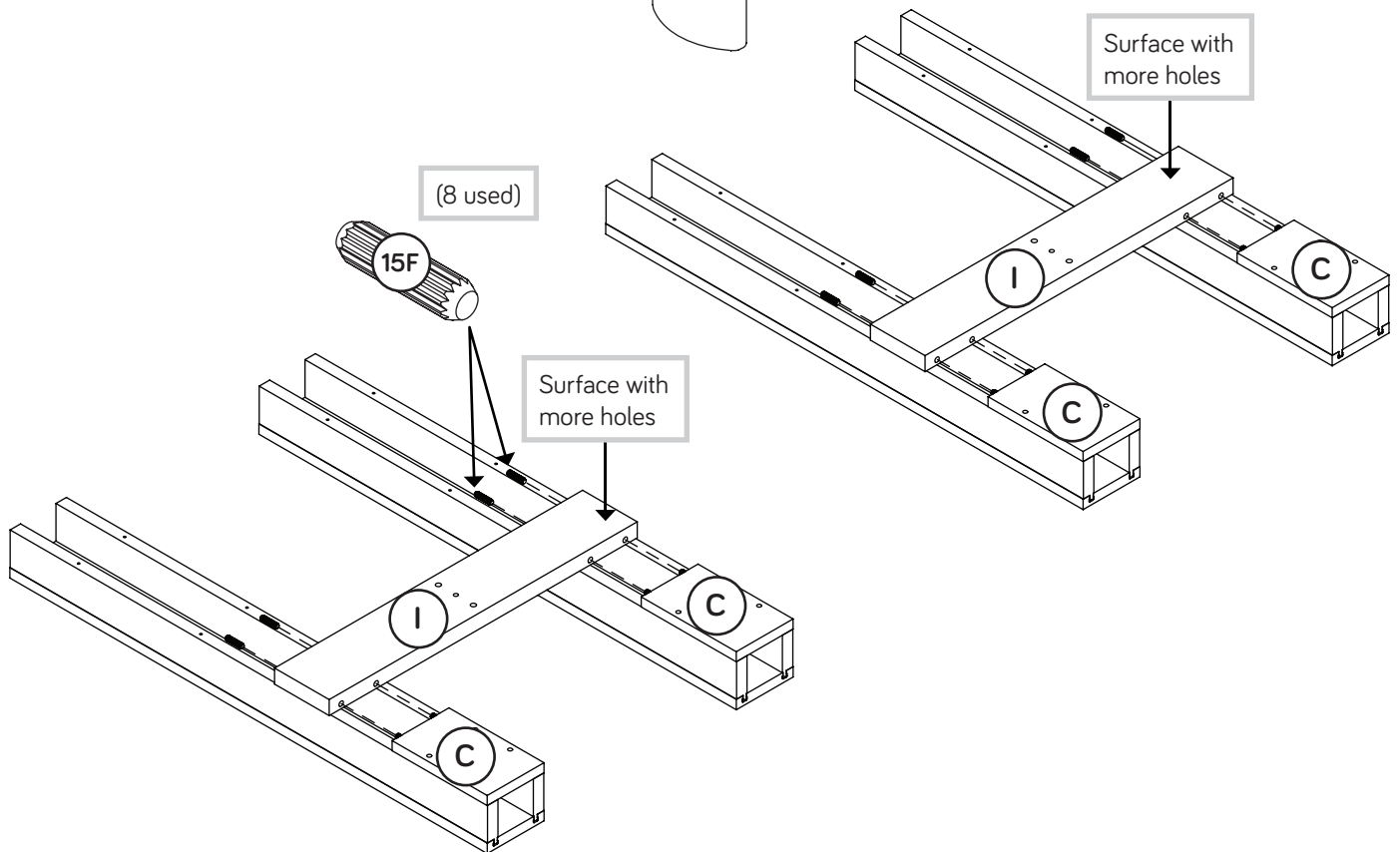

# Step 6

- ✚ Fill the holes in one end of each of the LONG LEG PANELS (B) 1/4 to 1/2 full with GLUE (54M).
- ✚ Next, place the LONG LEG PANELS (B) onto the WOOD DOWELS in the LOWER SHORT BRACES (I). Wipe away the excess GLUE.
- ✚ **NOTE:** Tap into place using a rubber mallet.
- ✚ Now, fasten the LONG LEG PANELS (B) to the LEG PANELS (E and K). Use twenty-four BLACK 1-7/8" FLAT HEAD SCREWS (2S).

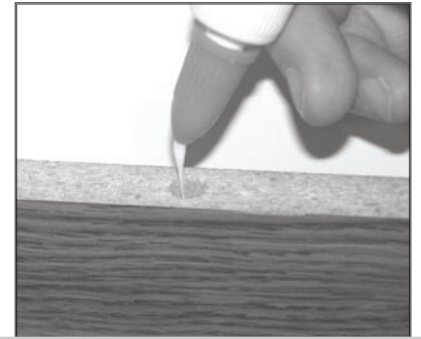

Fill the holes 1/4 to 1/2 full with GLUE.

## ⚠ Caution

Inspect the parts thoroughly before assembling. Disassembly of glued parts is extremely difficult.

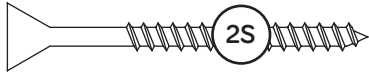
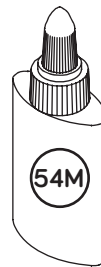

BLACK 1-7/8" FLAT HEAD SCREW  
(24 used in this step)

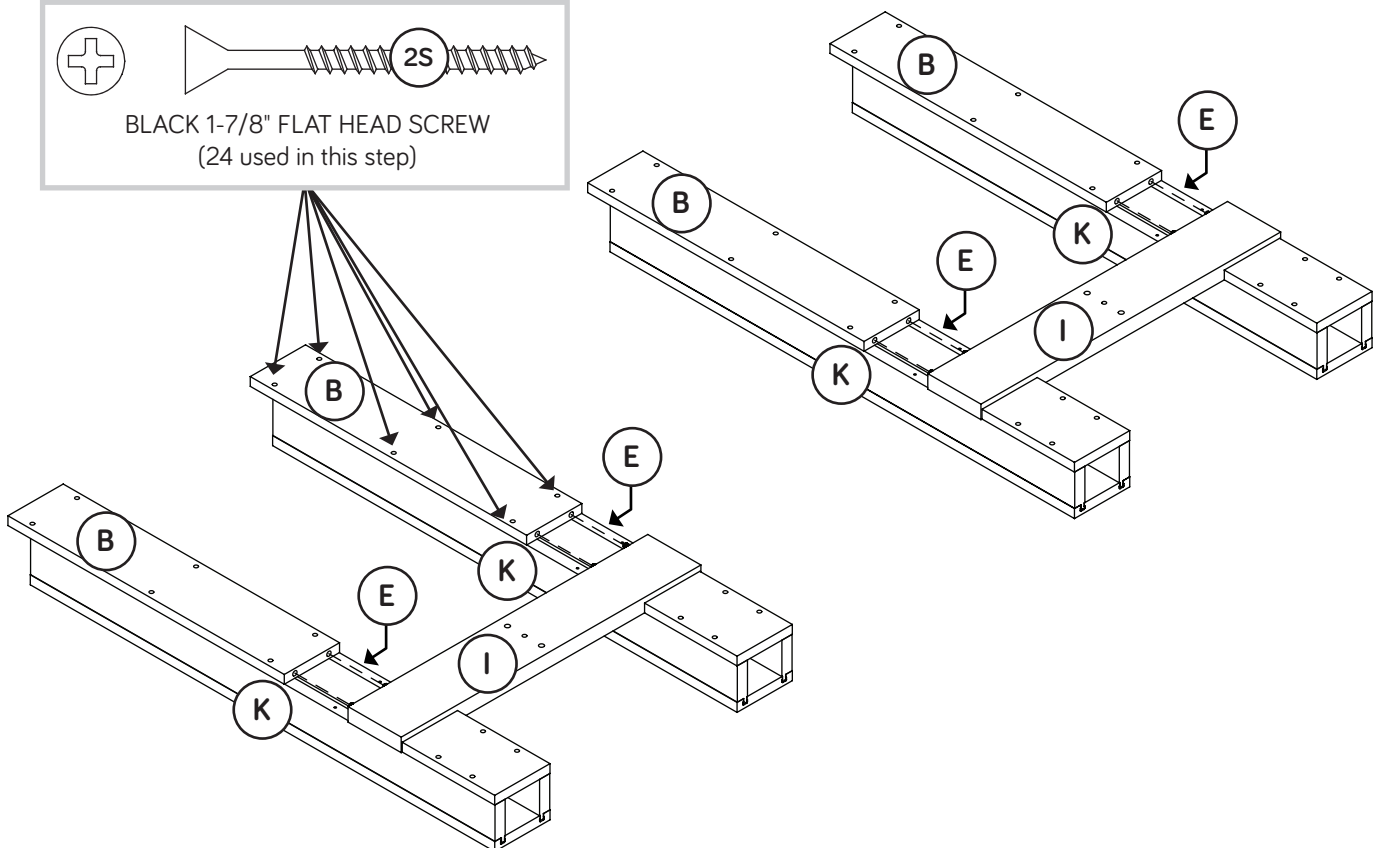

# Step 7

- Fasten the TOPS (A) to the TOP SHORT BRACES (G).  
Tighten eight TWIST-LOCK® FASTENERS.

**How to use the SAUDER TWIST-LOCK® FASTENER**

1. Insert the dowel end of the FASTENER into the hole of the adjoining part.

**NOTE:** The dowel end of the FASTENER must remain fully inserted in the hole of the adjoining part while locking the FASTENER.

2. Tighten the FASTENER with a Phillips screwdriver as tight as possible.

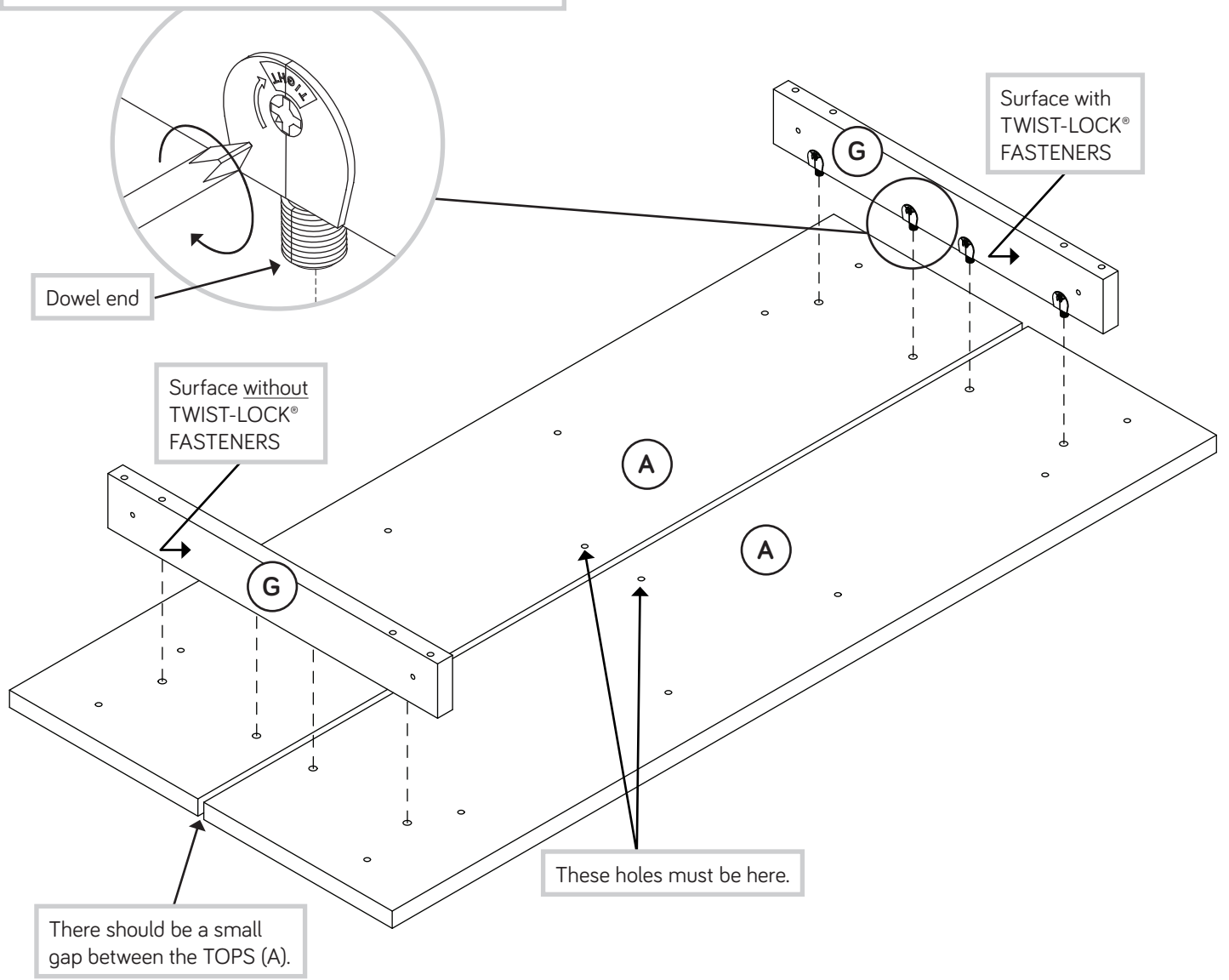

# Step 8

- Fasten the TOP LONG BRACES (F) and TOP CENTER BRACE (H) to the TOPS (A). Tighten ten HIDDEN CAMS.
- Fasten the TOP LONG BRACES (F) to the TOP SHORT BRACES (G). Use four SILVER 2" FLAT HEAD SCREWS (57S).
- Fasten the TOP LONG BRACES (F) to the TOP CENTER BRACE (H). Use two BLACK 1-7/8" FLAT HEAD SCREWS (2S).

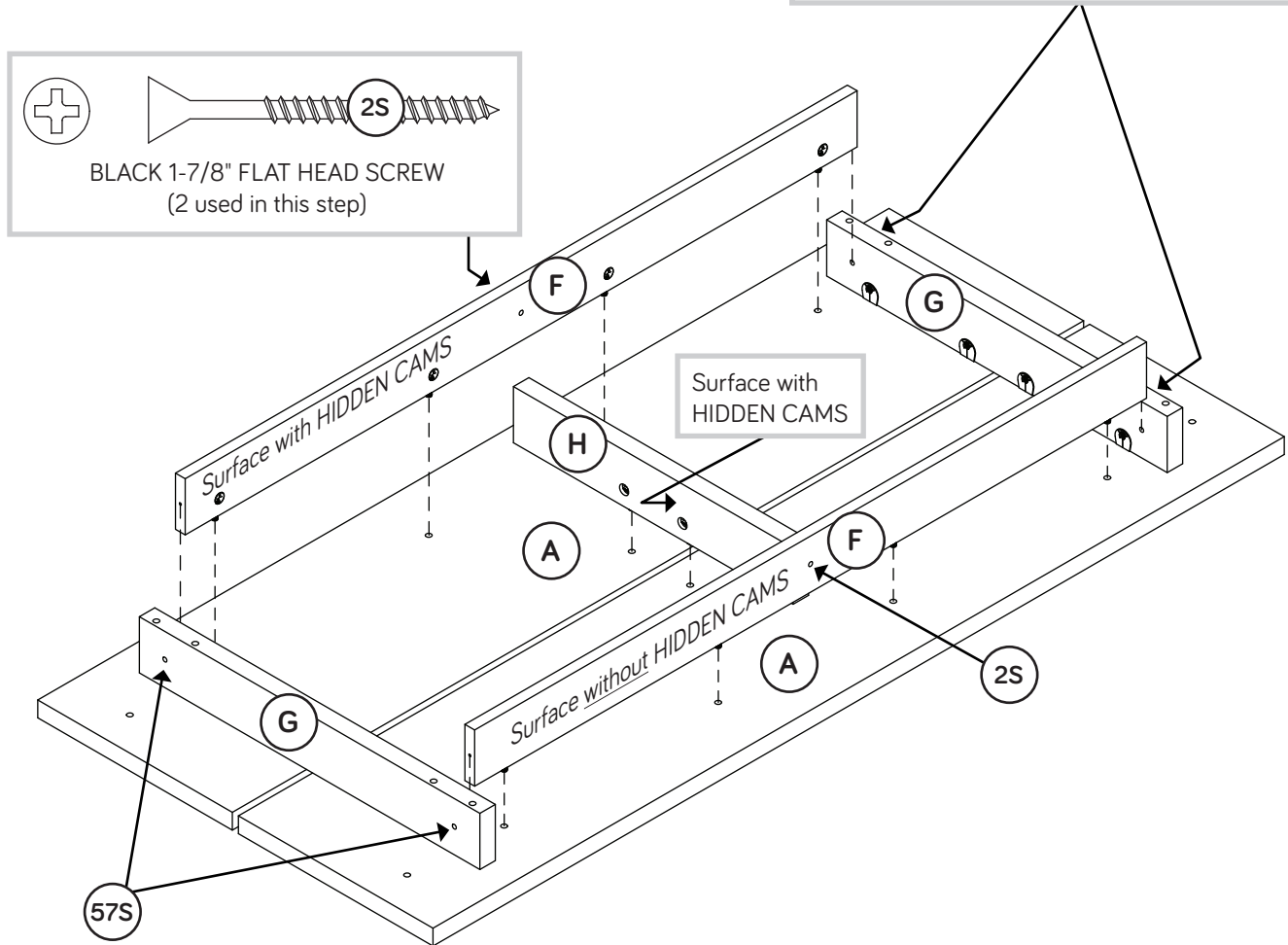
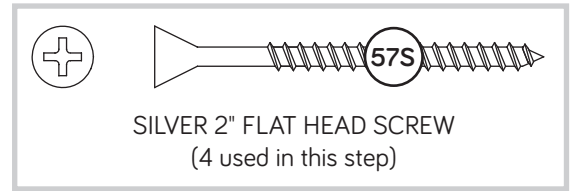
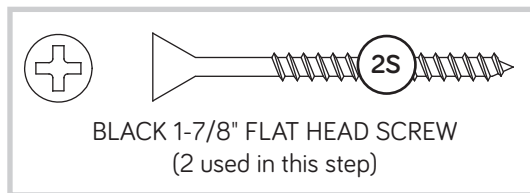

## ⚠ Caution

Risk of damage or injury. HIDDEN CAMS must be completely tightened. HIDDEN CAMS that are not completely tightened may loosen, and parts may separate. To completely tighten:

### Start

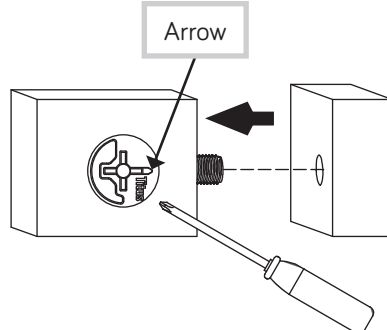

### Tighten

Maximum 210 degrees

Minimum 190 degrees

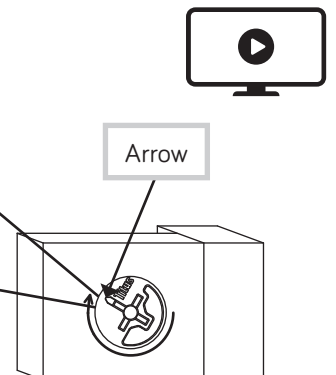

# Step 9

- ✚ **NOTE:** You will need someone's help in this step.
- ✚ First, fill the holes in the edge of the TOP SHORT BRACE (G) 1/4 to 1/2 full with GLUE (54M). Then, insert four WOOD DOWELS (15F) into the holes. Wipe away the excess GLUE.
- ✚ Next, place a dab of GLUE (54M) onto each WOOD DOWEL.
- ✚ Now, place the LONG LEGS PANELS (B) onto the WOOD DOWELS in the TOP SHORT BRACE (G). Wipe away the excess GLUE.
- ✚ **NOTE:** Be sure the CAM DOWELS in the OUTER LEG PANELS (D) insert into the holes in the TOPS (A).
- ✚ **NOTE:** Tap into place using a rubber mallet.
- ✚ Fasten the OUTER LEG PANELS (D) to the TOPS (A). Tighten two HIDDEN CAMS.

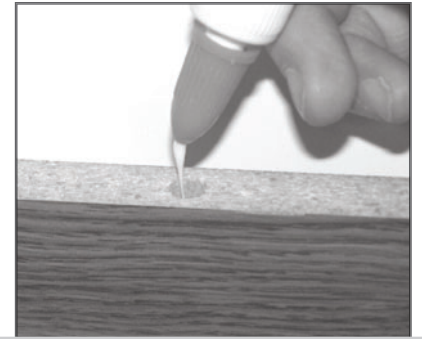

Fill the holes 1/4 to 1/2 full with GLUE.

## ⚠ Caution

Inspect the parts thoroughly before assembling. Disassembly of glued parts is extremely difficult.

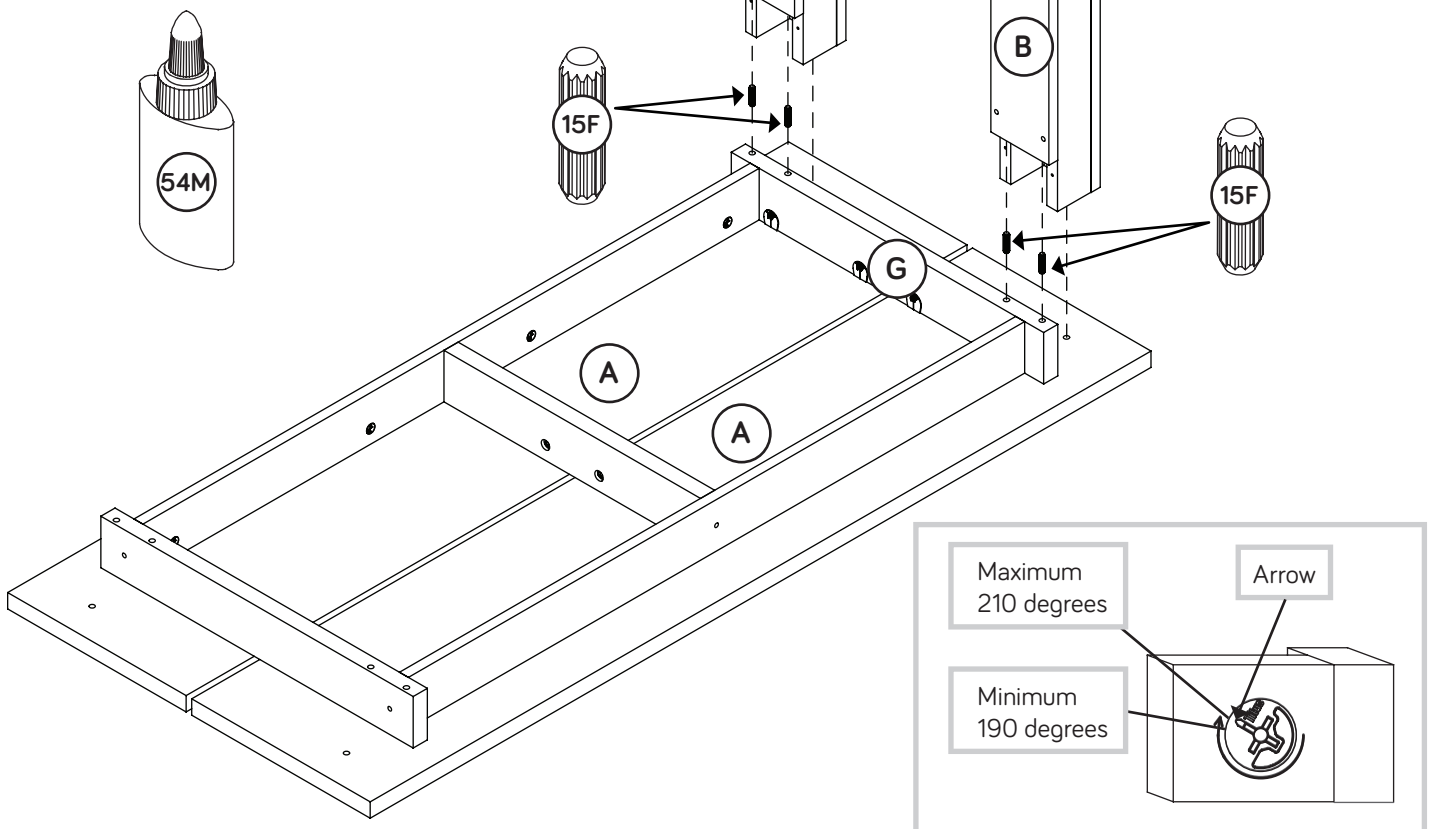

# Step 10

- ✚ **NOTE:** You will need someone's help in this step.
- ✚ Fill the outermost holes in the short edges of the LOWER LONG BRACE (J) 1/4 to 1/2 full with GLUE (54M). Then, insert four WOOD DOWELS (15F) into the holes. Wipe away the excess GLUE.
- ✚ Next, place a dab of GLUE (54M) onto each of the WOOD DOWELS in one end of the LOWER LONG BRACE (J).
- ✚ Now, insert the two WOOD DOWELS (dabbed with GLUE) into the holes in the LOWER SHORT BRACE (I).
- ✚ Fasten the LOWER LONG BRACE (J) to the LOWER SHORT BRACE (I). Use one SILVER 2" FLAT HEAD SCREW (57S).
- ✚ **NOTE:** You will need to support the loose end of the LOWER LONG BRACE (J) until it is fastened in the next step.

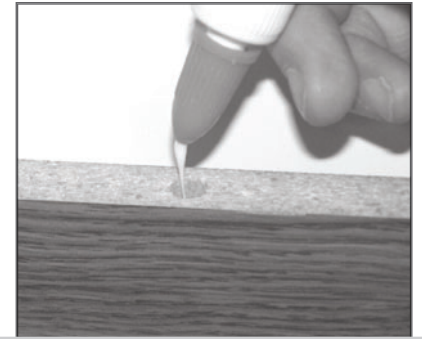

Fill the holes 1/4 to 1/2 full with GLUE.

## ⚠ Caution

Inspect the parts thoroughly before assembling. Disassembly of glued parts is extremely difficult.

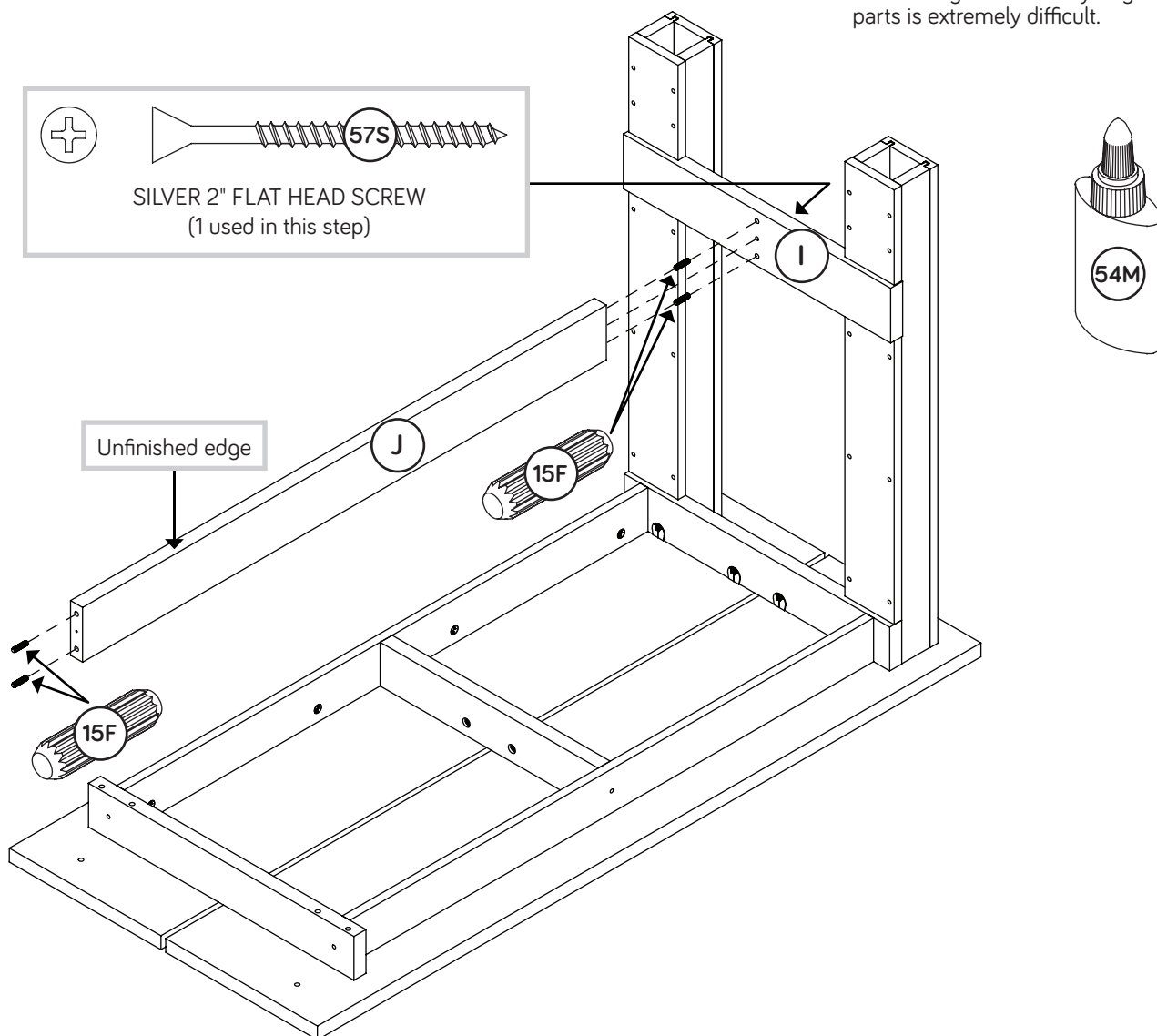

# Step 11

- ✦ First, fill the holes in the edge of the TOP SHORT BRACE (G) 1/4 to 1/2 full with GLUE (54M). Then, insert four WOOD DOWELS (15F) into the holes. Wipe away the excess GLUE.
- ✦ Next, place a dab of GLUE (54M) onto each WOOD DOWEL in the TOP SHORT BRACE (G) and LOWER LONG BRACE (J).
- ✦ Now, place the LONG LEGS PANELS (B) onto the WOOD DOWELS in the TOP SHORT BRACE (G). Wipe away the excess GLUE.
- ✦ NOTE: Be sure the CAM DOWELS in the OUTER LEG PANELS (D) insert into the holes in the TOPS (A). Also, be sure the WOOD DOWELS in the LOWER LONG BRACE (J) insert into the holes in the LOWER SHORT BRACE (I).
- ✦ NOTE: Tap into place using a rubber mallet.
- ✦ Fasten the OUTER LEG PANELS (D) to the TOPS (A). Tighten two HIDDEN CAMS.
- ✦ Fasten the LOWER SHORT BRACE (I) to the LOWER LONG BRACE (J). Use one SILVER 2" FLAT HEAD SCREW (57S).

## ⚠ Caution

Inspect the parts thoroughly before assembling. Disassembly of glued parts is extremely difficult.

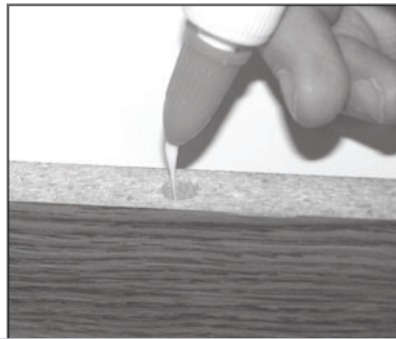

Fill the holes 1/4 to 1/2 full with GLUE.

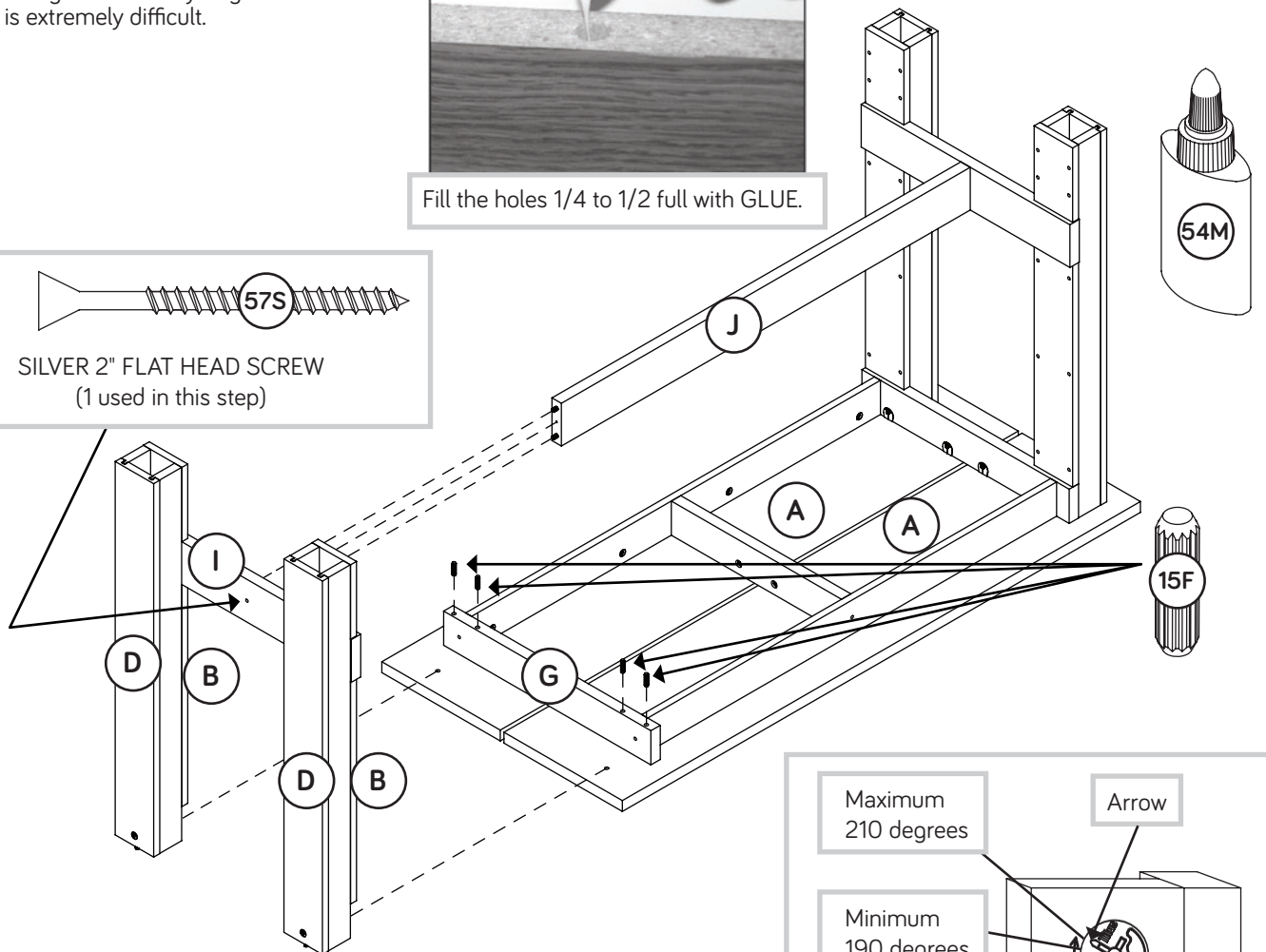
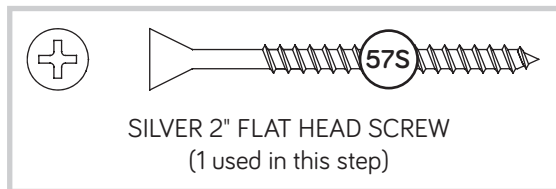

# Step 12

- ✚ Carefully stand your unit upright.
- ✚ Center a SCREW COVER (18P ) over the head of each SCREW and gently tap in with your rubber mallet.
- ✚ Using your rubber mallet, gently tap a CAM COVER (13P) onto each HIDDEN CAM.
- ✚ This completes assembly. Clean with your favorite furniture polish or a damp cloth. Wipe dry.

